



Request for Proposals (RFP) For Supply and Delivery of an Antenna Positioner to the CSIR Pretoria Campus

RFP No. 1186/26/03/2025

Date of Issue	12/03/2025	
Compulsory Briefing Session	Date and Time	19/03/2025 @ 13H30-15H30
	Requirement	Signed NDA – Annexure J signed and sent before briefing session to tender@csir.co.za
	Address	CSIR Building 44 ,Meiring Naudé Road Brummeria Pretoria South Africa
Enquiries	Strategic Procurement Unit	E-mail: tender@csir.co.za
	Please use RFP No and RFP Description as subject reference	
Last date for submission of enquiries/clarifications	24/03/2025 @ 16H30	
Electronical Submission	tender@csir.co.za (If tender submission exceeds 25MB multiple emails can be sent)	
CSIR business hours	08h00 – 16h30	
Category	Engineering Services	
Closing Date and Time	26 March 2025 @ 16H30	

TABLE OF CONTENTS

SECTION A	4
GENERAL RFP TERMS AND CONDITIONS	4
1 INTRODUCTION	4
2 SUBMISSION OF PROPOSALS	4
3 COUNTER CONDITIONS	5
4 FRONTING	5
5 PRICING PROPOSAL	6
6 APPOINTMENT OF SERVICE PROVIDER	6
7 ENQUIRIES AND CONTACT WITH THE CSIR	7
8 MEDIUM OF COMMUNICATION	7
9 CORRECTNESS OF RESPONSES	7
10 VERIFICATION OF DOCUMENTS	7
11 RESPONSIBILITY FOR SUB-CONTRACTORS AND BIDDER'S PERSONNEL	8
12 ADDITIONAL TERMS AND CONDITIONS	8
13 SPECIAL CONDITIONS	9
14 CONFLICT OF INTEREST, CORRUPTION AND FRAUD	10
15 MISREPRESENTATION DURING THE LIFECYCLE OF THE CONTRACT	11
16 PREPARATION COSTS AND LIMITATION OF LIABILITY	11
17 INDEMNITY	12
18 PRECEDENCE	12
19 TAX COMPLIANCE	12
20 TENDER DEFAULTERS AND RESTRICTED SUPPLIERS	13
21 GOVERNING LAW	13
22 CONFIDENTIALITY	13
23 AVAILABILITY OF FUNDS	14
24 PERSONAL INFORMATION	14
25 DISCLAIMER	15
SECTION B	16
EVALUATION METHODOLOGY	16
26 TERMS OF REFERENCE	16
27 EVALUATION CRITERIA	16
28 OBJECTIVE CRITERIA	17

29	NATIONAL TREASURY CENTRAL SUPPLIER DATABASE (CSD) REGISTRATION	18
	ABBREVIATIONS	23
	BACKGROUND	24

RFP STRUCTURE

SECTION A: GENERAL RFP TERMS AND CONDITIONS
SECTION B: EVALUATION METHODOLOGY / PROCESS

LIST OF ANNEXURES

- Annexure A – Standard Bidding Document (SBD) 1 Form
- Annexure B – Technical Specification
- Annexure C – Technical Evaluation Matrix/Rubrics
- Annexure D – Pricing Schedule
- Annexure E – Proposal Form and List of Returnable Documents
- Annexure F – Certificate of Acquaintance with RFP
- Annexure G – Preference Point Award Form
- Annexure H – Standard Bidding Document (SBD) 4 Form
- Annexure I – RFP Declaration and Breach of Law Form
- Annexure J – Mutual Non-Disclosure Agreement

SECTION A**GENERAL RFP TERMS AND CONDITIONS****1 INTRODUCTION**

The Council for Scientific and Industrial Research (CSIR) is one of the leading scientific research and technology development organisations in Africa. In partnership with national and international research and technology institutions, the CSIR undertakes directed and multidisciplinary research and technology innovation that contributes to the improvement of the quality of life of South Africans. The CSIR's main site is in Pretoria while it is represented in other provinces of South Africa through regional offices.

2 SUBMISSION OF PROPOSALS

- 2.1 All proposals are to be submitted electronically to tender@csir.co.za. No late proposals will be accepted.
- 2.2 All proposals will only be considered if received by the CSIR before the closing date and time (***as indicated on the cover page***). The CSIR business hours are between **08h00** and **16h30**.
- 2.3 All proposal submissions are to be clearly subject-referenced with the **RFP number and RFP Description**. Proposals must consist of two parts, each of which must be sent in two separate emails with the following subject:

PART 1: Technical Proposal (Please indicated the RFP Number on each File/folder)

PART 2: Pricing Proposal, Specific Goals claim documentation: RFP No.: (Please indicated the RFP Number on each File/folder)

- 2.4 Proposals submitted must be signed by a person or persons duly authorised.
- 2.5 Proposals submitted at incorrect location and/or address, will not be accepted for considerations and where practicable, will be returned unopened to the Bidder(s).

- 2.6 Proposals received after the closing date and time, at the address indicated in the bid documents, will not be accepted for consideration and where practicable, will be returned unopened to the Bidder(s).
- 2.7 All dates and times in this bid are South African standard time.
- 2.8 Any time or date in this bid is subject to change at the CSIR's discretion. The establishment of a time or date in this bid does not create an obligation on the part of the CSIR to take any action or create any right in any way for any bidder to demand that any action be taken on the date established. The bidder accepts that, if the CSIR extends the deadline for bid submission (the Closing Date) for any reason, the requirements of this bid otherwise apply equally to the extended deadline.
- 2.9 Documents submitted via cloud solutions such as: WeTransfer, Google Drive, Dropbox, etc. will not be considered.
- 2.10 The naming / labelling syntax of files or documents must be short and simple.
- 2.11 The CSIR will award the contract to qualified bidder(s)' whose proposal is determined to be the most advantageous to the CSIR, taking into consideration the technical (functional) solution, price, specific goals and objective criteria.

3 COUNTER CONDITIONS

Bidders' attention is drawn to the fact that amendments to any of the RFP Conditions or setting of counter conditions by Bidders or qualifying any RFP Conditions will result in the invalidation of such bids.

4 FRONTING

- 4.1 Government supports the spirit of broad based black economic empowerment and recognizes that real empowerment can only be achieved through individuals and businesses conducting themselves in accordance with the Constitution and in an honest, fair, equitable, transparent and legally compliant manner. Against this background the Government condemn any form of fronting.

- 4.2 The Government, in ensuring that Bidders conduct themselves in an honest manner will, as part of the RFP evaluation processes, conduct or initiate the necessary enquiries/investigations to determine the accuracy of the representation made in bid documents. Should any of the fronting indicators as contained in the Guidelines on Complex Structures and Transactions and Fronting, issued by the Department of Trade and Industry, be established during such enquiry / investigation, the onus will be on the Bidder / contractor to prove that fronting does not exist. Failure to do so within a period of 14 days from date of notification may invalidate the bid / contract and may also result in the restriction of the Bidder /contractor to conduct business with the public sector for a period not exceeding ten years, in addition to any other remedies the CSIR may have against the Bidder / contractor concerned.

5 PRICING PROPOSAL

- 5.1 Pricing must be provided in South African Rand (including all applicable taxes less all unconditional discounts).
- 5.2 Prices that are subject to escalation and exchange rate fluctuations are to be clearly indicated, with the currency and ROE used in the quotation must be clearly indicated.
- 5.3 Price should include additional cost elements such as travel cost, freight, insurance until acceptance, duty where applicable, etc.
- 5.4 Payment will be according to the [CSIR Payment Terms and Conditions](#).
- 5.5 Please provide a detail pricing using a Pricing Schedule/Bill of Quantities outlined under **Annexure D. Pricing must strictly be in accordance with the Pricing Schedule.**

6 APPOINTMENT OF SERVICE PROVIDER

- 6.1 The contract will be awarded to the bidder who scores the highest total number of points during the evaluation process, except where the law permits otherwise.
- 6.2 Appointment as a successful service provider shall be subject to the parties agreeing to mutually acceptable contractual terms and conditions. In the event of the parties failing to reach such agreement, CSIR reserves the right to appoint an alternative supplier.

6.3 Awarding of contracts will be published on the same platform where the bid was published, and no regret letters will be sent to unsuccessful bidders.

6.4 The CSIR reserves the right to accept or reject any or all amendments or additions proposed by a bidder if such amendments or additions are unacceptable to the CSIR or pose a risk to the organisation.

7 ENQUIRIES AND CONTACT WITH THE CSIR

Any enquiry regarding this RFP shall be submitted in writing to CSIR to the email and format outlined in the table on cover page of this RFP document.

Any other contact with CSIR personnel involved in this tender is not permitted during the RFP process other than as required through existing service arrangements or as requested by the CSIR as part of the RFP process.

8 MEDIUM OF COMMUNICATION

All documentation submitted in response to this RFP must be in English.

9 CORRECTNESS OF RESPONSES

9.1 The bidder must confirm satisfaction regarding the correctness and validity of their proposal and that all prices and rates quoted cover all the work/items specified in the RFP. The prices and rates quoted must cover all obligations under any resulting contract.

9.2 The bidder accepts that any mistakes regarding prices and calculations will be at their own risk.

10 VERIFICATION OF DOCUMENTS

10.1 Bidders should check the numbers of the pages to satisfy themselves that none is missing or duplicated. No liability will be accepted by the CSIR in regard to anything arising from the fact that pages are missing or duplicated.

- 10.2 Pricing schedule and specific goals credentials should be submitted with the proposal, but as a separate document and no such information should be available in the technical proposal.

11 RESPONSIBILITY FOR SUB-CONTRACTORS AND BIDDER'S PERSONNEL

A bidder is responsible for ensuring that its personnel (including agents, officers, directors, employees, advisors and other representatives), its sub-contractors (if any) and personnel of its sub-contractors comply with all terms and conditions of this bid. In the event that the CSIR allows a bidder to make use of sub-contractors, such sub-contractors will at all times remain the responsibility of the bidder and the CSIR will not under any circumstances be liable for any losses or damages incurred by or caused by such sub-contractors.

12 ADDITIONAL TERMS AND CONDITIONS

- 12.1 A bidder shall not assume that information and/or documents supplied to CSIR, at any time prior to this request, are still available to CSIR, and shall consequently not make any reference to such information document in its response to this request.
- 12.2 Copies of any affiliations, memberships and/or accreditations that support your submission must be included in the tender.
- 12.3 In case of proposal/s from a joint venture, the following must be submitted together with the proposal/s:
- A joint venture agreement signed by both parties clearly indication the lead partner, including split of work;
 - Copy of a valid certificate or consolidated B-BBEE score card;
 - The Tax Compliance Status (TCS) or CSD Report of each joint venture partner;
 - Proof of ownership/shareholder certificates/copies; and
 - Company registration certificate/s.

- 12.4 An omission to disclose material information, a factual inaccuracy, and/or a misrepresentation of fact may result in the disqualification of a tender, or cancellation of any subsequent contract.
- 12.5 No goods and/or services should be delivered to the CSIR without an official CSIR Purchase order or signed supplier agreement. The CSIR purchase order number must be quoted on the invoice. Invoices without CSIR purchase order numbers will be returned to supplier.
- 12.6 Failure to comply with any of the terms and conditions as set out in this document will invalidate the Proposal.

13 SPECIAL CONDITIONS

The CSIR reserves the right to:

- 13.1 Extend the closing date of this RFP;
- 13.2 Correct any mistakes before closing date and time of the tender that may have been in the Bid documents or occurred at any stage of the tender process;
- 13.3 Verify any information contained in the bidder's submission;
- 13.4 Request documentary proof regarding the bidder's submission;
- 13.5 Carry out site inspections, product evaluations or explanatory meetings in order to verify the nature and quality of the product/service offered by the bidder(s) or verify any information whether before or after the adjudication of this RFP;
- 13.6 Award this tender to a bidder that did not score the highest total number of points, only in accordance with Section 2(1)(f) of the PPPFA (Act 5 of 2000);
- 13.7 Request audited financial statements or other documents for the purpose of a due diligence exercise to determine if the bidder will be able to execute the contract;
- 13.8 Award this RFP as a whole or in part;

13.9 Award this RFP to multiple bidders;

13.10 Cancel and/or terminate the tender process at any stage, including after the Closing Date and/or after presentations have been made, and/or after tenders have been evaluated and/or after the preferred bidder(s) have been notified of their status as such;

13.11 Post tender negotiate on any elements on the bid, including but not limited to technical, transformation, price, and contractual terms and conditions.;

13.12 Not to award a contract to a bidder who is associated with a security breach that materially adversely affects other entities or if any directors or officers of a bidder are formally charged of fraudulent or illegal conduct which, would harm the CSIR's reputation by its continued association with the bidder.

14 CONFLICT OF INTEREST, CORRUPTION AND FRAUD

14.1 The CSIR reserves its right to disqualify any bidder who either itself or any of whose members (save for such members who hold a minority interest in the bidder through shares listed on any recognised stock exchange), indirect members (being any person or entity who indirectly holds at least a 15% interest in the bidder other than in the context of shares listed on a recognised stock exchange), directors or members of senior management, whether in respect of CSIR or any other government organ or entity and whether from the Republic of South Africa or otherwise ("Government Entity")

- a. engages in any collusive tendering, anti-competitive conduct, or any other similar conduct, including but not limited to any collusion with any other bidder in respect of the subject matter of this bid;
- b. seeks any assistance, other than assistance officially provided by a Government Entity, from any employee, advisor or other representative of a Government Entity in order to obtain any unlawful advantage in relation to procurement or services provided or to be provided to a Government Entity;
- c. makes or offers any gift, gratuity, anything of any value or other inducement, to any Government Entity's officers, directors, employees, advisors or other representatives

in order to obtain any unlawful advantage in relation to procurement or services provided or to be provided to a Government Entity;

- d. accepts anything of value or an inducement that would or may provide financial gain, advantage or benefit in relation to procurement or services provided or to be provided to a Government Entity;
- e. pays or agrees to pay to any person any fee, commission, percentage, brokerage fee, gift or any other consideration, that is contingent upon or results from, the award of any tender, contract, right or entitlement which is in any way related to procurement or the rendering of any services to a Government Entity;
- f. has in the past engaged in any matter referred to above; or
- g. has been found guilty in a court of law on charges of fraud and/or forgery, regardless of whether or not a prison term was imposed and despite such bidder, member or director's name not specifically appearing on the List of Tender Defaulters kept at National Treasury.

15 MISREPRESENTATION DURING THE LIFECYCLE OF THE CONTRACT

15.1 The bidder should note that the terms of its Tender will be incorporated in the proposed contract by reference and that the CSIR relies upon the bidder's Tender as a material representation in making an award to a successful bidder and in concluding an agreement with the bidder.

15.2 It follows therefore that misrepresentations in a Tender may give rise to service termination and a claim by the CSIR against the bidder notwithstanding the conclusion of the Service Level Agreement between the CSIR and the bidder for the provision of the Service in question. In the event of a conflict between the bidder's proposal and the Service Level Agreement concluded between the parties, the Service Level Agreement will prevail.

16 PREPARATION COSTS AND LIMITATION OF LIABILITY

The Bidder will bear all its costs in preparing, submitting and presenting any response or Tender to this bid and all other costs incurred by it throughout the bid process.

Furthermore, no statement in this bid will be construed as placing the CSIR, its employees or agents under any obligation whatsoever, including in respect of costs, expenses or losses incurred by the bidder(s) in the preparation of their response to this bid.

A bidder participates in this bid process entirely at its own risk and cost. The CSIR shall not be liable to compensate a bidder on any grounds whatsoever for any costs incurred or any damages suffered as a result of the Bidder's participation in this Bid process.

17 INDEMNITY

If a bidder breaches the conditions of this bid and, as a result of that breach, the CSIR incurs costs or damages (including, without limitation, the cost of any investigations, procedural impairment, repetition of all or part of the bid process and/or enforcement of intellectual property rights or confidentiality obligations), then the bidder indemnifies and holds the CSIR harmless from any and all such costs which the CSIR may incur and for any damages or losses the CSIR may suffer.

18 PRECEDENCE

This document will prevail over any information provided during any briefing session whether oral or written, unless such written information provided, expressly amends this document by reference.

19 TAX COMPLIANCE

No tender shall be awarded to a bidder who is not tax compliant. If a recommended bidder is not tax compliant, the bidder will be notified in writing of their non-compliant status and the bidder will be requested to submit written proof from SARS of their tax compliant status or proof that they have made an arrangement to meet their outstanding tax obligations within seven (7) working days. Should they fail to do so CSIR will reject their bid.

The CSIR reserves the right to withdraw an award made, or cancel a contract concluded with a successful bidder in the event that it is established that such bidder was in fact not

tax compliant at the time of the award or has submitted a fraudulent Tax Clearance Certificate to the CSIR, or whose verification against the Central Supplier Database (CSD) proves non-compliant. The CSIR further reserves the right to cancel a contract with a successful bidder in the event that such bidder does not remain tax compliant for the full term of the contract.

20 TENDER DEFAULTERS AND RESTRICTED SUPPLIERS

No tender shall be awarded to a bidder whose name (or any of its members, directors, partners or trustees) appear on the Register of Tender Defaulters kept by National Treasury, or who have been placed on National Treasury's List of Restricted Suppliers. The CSIR reserves the right to withdraw an award, or cancel a contract concluded with a Bidder should it be established, at any time, that a bidder has been blacklisted with National Treasury by another government institution.

21 GOVERNING LAW

South African law governs this bid and the bid response process. The bidder agrees to submit to the exclusive jurisdiction of the South African courts in any dispute of any kind that may arise out of or in connection with the subject matter of this bid, the bid itself and all processes associated with the bid.

22 CONFIDENTIALITY

Except as may be required by operation of law, by a court or by a regulatory authority having appropriate jurisdiction, no information contained in or relating to this bid or a bidder's tender(s) will be disclosed by any bidder or other person not officially involved with the CSIR's examination and evaluation of a Tender.

No part of the bid may be distributed, reproduced, stored or transmitted, in any form or by any means, electronic, photocopying, recording or otherwise, in whole or in part except for the purpose of preparing a Tender. This bid and any other documents supplied by the CSIR remain proprietary to the CSIR and must be promptly returned to the CSIR upon

request together with all copies, electronic versions, excerpts or summaries thereof or work derived there from.

Throughout this bid process and thereafter, bidder(s) must secure the CSIR's written approval prior to the release of any information that pertains to (i) the potential work or activities to which this bid relates; or (ii) the process which follows this bid. Failure to adhere to this requirement may result in disqualification from the bid process and civil action.

23 AVAILABILITY OF FUNDS

Should funds no longer be available to pay for the execution of the responsibilities of this bid, the CSIR may terminate the Agreement at its own discretion or temporarily suspend all or part of the services by notice to the successful bidder who shall immediately make arrangements to stop the performance of the services and minimize further expenditure: Provided that the successful bidder shall thereupon be entitled to payment in full for the services delivered, up to the date of cancellation or suspension.

24 PERSONAL INFORMATION

24.1 Each Party consents to the other Party holding and processing "personal information" (as defined in the POPI Act) relating to it for legal, personnel, administrative and management purposes (including, if applicable, any "special personal information" relating to him/her, as defined in the POPI Act). Notwithstanding the generality of the aforesaid, each Party hereby undertakes to comply with all relevant provisions of the POPI Act and any other applicable data protection laws. The bidder further agrees to comply with all CSIR's reasonable internal governance requirements pertaining to data protection.

24.2 Each Party consents to the other Party making such information available to those who provide products or services to such parties (such as advisers, regulatory authorities, governmental or quasi-governmental organisations and potential purchasers of such Party or any part of their business).

24.3 While performing any activity where a Party is handling personal information as a "responsible party" (as defined in the POPI Act), each Party undertakes that it will process

the personal information strictly in accordance with the terms of the POPI Act, this Contract, and the other Party's instructions from time to time, and take appropriate operational measures to safeguard the data against any unauthorised access.

24.4 Each Party acknowledges that in the course of conducting business with each other, each Party intends to maintain and process personal information about the other Party in an internal database. By signing this Contract, each Party consents to the maintenance and processing of such personal information.

Where relevant, the bidder shall procure that all of its personnel, agents, representatives, contractors, sub-contractors and mandataries shall comply with the provisions of this clause 30 (Personal Information). The CSIR shall be entitled on reasonable notice to conduct an inspection or audit bidders compliance with the requisite POPI Act safeguards.

25 DISCLAIMER

This RFP is a request for proposals only and not an offer document. Answers to this RFP must not be construed as acceptance of an offer or imply the existence of a contract between the parties. By submission of its proposal, bidders shall be deemed to have satisfied themselves with and to have accepted all Terms & Conditions of this RFP. The CSIR makes no representation, warranty, assurance, guarantee or endorsements to bidder concerning the RFP, whether with regard to its accuracy, completeness or otherwise and the CSIR shall have no liability towards the bidder or any other party in connection therewith.

SECTION B

EVALUATION METHODOLOGY

26 TERMS OF REFERENCE

This RFP is for the provision of antenna positioner for the Inundu airborne pod. The service offering must include all requirements as set out in **Annexure B**.

27 EVALUATION CRITERIA

The CSIR has set minimum standards that a bidder needs to meet in order to be evaluated and selected as a successful bidder. The minimum standards consist of the following:

Elimination Criteria (Phase 1)	Technical Evaluation Criteria (Phase 2)	Price and Preference Points Evaluation (Phase 3)	Objective Criteria
Only bidders that comply with ALL the criteria set on paragraph 27.1 on Phase 1 below will proceed to Technical/Functional Evaluation (Phase 2).	Bidder(s) are required to achieve a predetermined minimum threshold of 40% on each of the individual criteria, and a predetermined minimum threshold of 70% overall. Only bidder (s) who met and/or exceeded the minimum threshold points on Phase 2 below will proceed to Price and Preference Points Evaluation. (Phase 3)	Bidder(s) will be evaluated out of 100 points i.e. 80 or 90 points for Price and 20 or 10 points for Preference Points.	The CSIR reserves the right to award this tender to a bidder that did not score the highest total number of points in accordance with Section (2) (1) (f) of the PPPFA (Act 5 of 2000).

27.1 Elimination Criteria (Phase 1)

Proposals will be eliminated under the following conditions:

- Bidder that submitted late bids will not be considered.
- Bidder that submitted to the incorrect location or email address will not be considered (Only electronic submission to tender@csir.co.za would be considered).
- Bidder that is listed on the NT database of restricted suppliers will not be considered.
- Bidder that is registered on the NT Register of Tender Defaulters will not be considered.

- Bidder that did not submit mandatory returnable documents as listed on **Annexure E: Proposal Form and List of Returnable Documents (Mandatory Returnable Documents Table)**.
- Bidder that did not attend the compulsory briefing session.

27.2 Technical Evaluation Criteria (Phase 2)

The evaluation of the functional / technical detail of the proposal will be based on the following criteria:

No	CRITERIA	SCORE
1	Mechanical design	15%
2	Mechanical manufacturing	10%
3	Experience – previous projects	40%
4	Support to integrate positioner with POD's control system	10%
5	Delivery schedule for antenna positioner	25%
TOTAL (%)		100%

Proposals with functionality / technical points of less than the pre-determined minimum overall percentage of **70%** and less than **40%** on each of the individual criteria will be eliminated from further evaluation on Price and Preference Points Evaluation.

Refer to **Annexure C (Technical Evaluation Matrix/Rubrics)** for the scoring ranges/rubrics that will be used to evaluate functionality.

27.3 Price and Preference Points Evaluation (Phase 3)

Only Bidders that have met meet minimum thresholds on Technical/functional Evaluation will be evaluated for price and preference points. Price and Preference Points will be evaluated as per **Annexure G: Preference Points Award Form**.

28 OBJECTIVE CRITERIA

The CSIR reserves the right to award this tender to a bidder that did not score the highest total number of points in accordance with Section (2) (1) (f) of the PPPFA (Act 5 of 2000)", under the following conditions:

- The directors, shareholders or officers of the bidder must not be formally charged of fraudulent or illegal conduct which could harm the CSIR's reputation by associating with the bidder.

29 NATIONAL TREASURY CENTRAL SUPPLIER DATABASE (CSD) REGISTRATION

Respondents are required to self-register on National Treasury's Central Supplier Database (CSD) which has been established to centrally administer supplier information for all organs of state and facilitate the verification of certain key supplier information. Business may not be awarded to a Respondent who has failed to register on the CSD. Only foreign suppliers with no local registered entity need not register on the CSD. In order to enable the CSIR to verify information on the CSD, Respondents are required to provide the unique registration reference number.

Before any negotiations will start with the winning bidder it will be required from the winning bidder to:

- be registered on National Treasury's Central Supplier Database (CSD). Registrations can be completed online at: www.csd.gov.za;
- provide the CSIR of their CSD registration number.

Annexure A

Standard Bidding Document (SBD) 1

PART A: INVITATION TO BID

YOU ARE HEREBY INVITED TO BID FOR REQUIREMENTS OF THE CSIR					
BID NUMBER:	1186/26/03/2025	CLOSING DATE:	26/03/2025	CLOSING TIME:	16:30
DESCRIPTION	Request for Proposals (RFP) for Supply and Delivery of an Antenna Positioner to the CSIR				
BID RESPONSE DOCUMENTS MAY BE DEPOSITED IN THE BID BOX SITUATED AT (STREET ADDRESS)					
The CSIR requires that all tender submissions be submitted electronically to tender@csir.co.za . Should tender file size exceed 25MB, bidders submit tender in multiple emails. Use the tender number and description of the tender as the subject on your email.					
BIDDING PROCEDURE ENQUIRIES MAY BE DIRECTED TO			TECHNICAL ENQUIRIES MAY BE DIRECTED TO:		
CONTACT PERSON		CONTACT PERSON			
TELEPHONE NUMBER		TELEPHONE NUMBER			
FACSIMILE NUMBER		FACSIMILE NUMBER			
E-MAIL ADDRESS	tender@csir.co.za	E-MAIL ADDRESS		tender@csir.co.za	
SUPPLIER INFORMATION					
NAME OF BIDDER					
POSTAL ADDRESS					
STREET ADDRESS					
TELEPHONE NUMBER	CODE		NUMBER		
CELLPHONE NUMBER					
FACSIMILE NUMBER	CODE		NUMBER		
E-MAIL ADDRESS					
VAT REGISTRATION NUMBER					
SUPPLIER COMPLIANCE STATUS	TAX COMPLIANCE SYSTEM PIN:		OR	CENTRAL SUPPLIER DATABASE No:	MAAA
1 ARE YOU THE ACCREDITED REPRESENTATIVE IN SOUTH AFRICA FOR THE GOODS /SERVICES /WORKS OFFERED?	<input type="checkbox"/> Yes <input type="checkbox"/> No [IF YES ENCLOSE PROOF]		2 ARE YOU A FOREIGN BASED SUPPLIER FOR THE GOODS /SERVICES /WORKS OFFERED?	<input type="checkbox"/> Yes <input type="checkbox"/> No [IF YES, ANSWER THE QUESTIONNAIRE BELOW]	
QUESTIONNAIRE TO BIDDING FOREIGN SUPPLIERS					
IS THE ENTITY A RESIDENT OF THE REPUBLIC OF SOUTH AFRICA (RSA)?					<input type="checkbox"/> YES

<input type="checkbox"/> NO	
DOES THE ENTITY HAVE A BRANCH IN THE RSA?	<input type="checkbox"/> YES <input type="checkbox"/> NO
DOES THE ENTITY HAVE A PERMANENT ESTABLISHMENT IN THE RSA?	<input type="checkbox"/> YES <input type="checkbox"/> NO
DOES THE ENTITY HAVE ANY SOURCE OF INCOME IN THE RSA?	<input type="checkbox"/> YES <input type="checkbox"/> NO
IS THE ENTITY LIABLE IN THE RSA FOR ANY FORM OF TAXATION?	<input type="checkbox"/> YES <input type="checkbox"/> NO
IF THE ANSWER IS “NO” TO ALL OF THE ABOVE, THEN IT IS NOT A REQUIREMENT TO REGISTER FOR A TAX COMPLIANCE STATUS SYSTEM PIN CODE FROM THE SOUTH AFRICAN REVENUE SERVICE (SARS) AND IF NOT REGISTER AS PER 2.3 BELOW.	

PART B: TERMS AND CONDITIONS FOR BIDDING

- 1. BID SUBMISSION:**
- 1.1. BIDS MUST BE DELIVERED BY THE STIPULATED TIME TO THE CORRECT ADDRESS. LATE BIDS WILL NOT BE ACCEPTED FOR CONSIDERATION.
 - 1.2. **ALL BIDS MUST BE SUBMITTED ON THE OFFICIAL FORMS PROVIDED–(NOT TO BE RE-TYPED) OR IN THE MANNER PRESCRIBED IN THE BID DOCUMENT.**
 - 1.3. THIS BID IS SUBJECT TO THE PREFERENTIAL PROCUREMENT POLICY FRAMEWORK ACT, 2000 AND THE PREFERENTIAL PROCUREMENT REGULATIONS, 2022, THE GENERAL CONDITIONS OF CONTRACT (GCC) AND, IF APPLICABLE, ANY OTHER SPECIAL CONDITIONS OF CONTRACT.
 - 1.4. **THE SUCCESSFUL BIDDER WILL BE REQUIRED TO FILL IN AND SIGN A WRITTEN CONTRACT FORM (SBD7).**

- 2. TAX COMPLIANCE REQUIREMENTS**
- 2.1 BIDDERS MUST ENSURE COMPLIANCE WITH THEIR TAX OBLIGATIONS.
 - 2.2 BIDDERS ARE REQUIRED TO SUBMIT THEIR UNIQUE PERSONAL IDENTIFICATION NUMBER (PIN) ISSUED BY SARS TO ENABLE THE ORGAN OF STATE TO VERIFY THE TAXPAYER’S PROFILE AND TAX STATUS.
 - 2.3 APPLICATION FOR TAX COMPLIANCE STATUS (TCS) PIN MAY BE MADE VIA E-FILING THROUGH THE SARS WEBSITE WWW.SARS.GOV.ZA.
 - 2.4 BIDDERS MAY ALSO SUBMIT A PRINTED TCS CERTIFICATE TOGETHER WITH THE BID.
 - 2.5 IN BIDS WHERE CONSORTIA / JOINT VENTURES / SUB-CONTRACTORS ARE INVOLVED, EACH PARTY MUST SUBMIT A SEPARATE TCS CERTIFICATE / PIN / CSD NUMBER.
 - 2.6 WHERE NO TCS PIN IS AVAILABLE BUT THE BIDDER IS REGISTERED ON THE CENTRAL SUPPLIER DATABASE (CSD), A CSD NUMBER MUST BE PROVIDED.
 - 2.7 NO BIDS WILL BE CONSIDERED FROM PERSONS IN THE SERVICE OF THE STATE, COMPANIES WITH DIRECTORS WHO ARE PERSONS IN THE SERVICE OF THE STATE, OR CLOSE CORPORATIONS WITH MEMBERS PERSONS IN THE SERVICE OF THE STATE.”

NB: FAILURE TO PROVIDE / OR COMPLY WITH ANY OF THE ABOVE PARTICULARS MAY RENDER THE BID INVALID.

SIGNATURE OF BIDDER:

CAPACITY UNDER WHICH THIS BID IS SIGNED:
 (Proof of authority must be submitted e.g. company resolution)

DATE:

Annexure B

Technical Specification/Scope of Services for the supply and delivery of an Antenna Positioner to the CSIR

1. INVITATION FOR PROPOSAL

Proposals are hereby invited for the supply and delivery of an Antenna positioner for the Inundu airborne pod to the CSIR.

The purpose of the Request for Proposal (RFP) is to obtain capability, pricing and general information on the business of potential Contractors for the CSIR to determine the Contractors most capable of providing the service.

This RFP document details and incorporates, as far as possible, the tasks and responsibilities of the potential bidder required by the CSIR.

This RFP does not constitute an offer to do business with the CSIR, but merely serves as an invitation to bidder(s) to facilitate a requirements-based decision process.

Responses to this Request for Proposal (RFP) (hereinafter referred to as a Bid or a Proposal) are requested from suitably qualified entities (hereinafter referred to as a Respondent or Bidder) for the provision of Antenna Positioner for the Inundu airborne pod.

2. PROPOSAL REQUIREMENTS

3. All proposals are to be submitted in a format specified in this enquiry. However, bidders are welcome to submit additional / alternative proposals over and above the originally specified format.

3.1. Technical Proposal

The following must be submitted as part of the **technical** proposal:

- a. Company profile.
- b. Detailed Technical Proposal
- c. Signed NDA – this is required before the compulsory briefing session.

3.2. Financial Proposal:

The following must be submitted as part of the **financial** proposal:

- Cover Letter.
- Completed Pricing Schedule (**Annexure D**) on official company letterhead.
- CSD registration report (RSA suppliers only).
- The pricing must be firm and inclusive of all costs and disbursements required to render the required services to the CSIR.

4. PROPOSAL SPECIFICATION

Abbreviations

ATP	Acceptance Test Procedure
CAD	Computer Aided Design
COG	Centre of Gravity
COTS	Commercial Off The Shelf
CSIR	Council for Scientific and Industrial Research
D&S	Defence and Security
EM	Electromagnetic
EW	Electronic Warfare
MOI	Moment of Inertia
MW	Microwave
RF	Radio Frequency

4.1. Scope of Work

Purpose

This document contains the requirements for an antenna positioning system to be used with a 340 mm diameter Cassegrain antenna located within the nosecone of the Inundu-3 airborne pod. The requirements are roughly divided into several classes: size constraints (within the pod), weight constraints (including effect upon the pod centre-of-gravity (COG), and moment-of-inertia (MOI)), functionality (describing how the antenna positioner should operate in response to a set of communicated commands), communications (how position is communicated with the positioner), and power-supply.

Definitions

i. “shall”

Indicates a mandatory requirement that must be met for contractual compliance and fulfilment. Requirements stated with this qualifier form the minimum set of requirements to be met for the delivery to be deemed acceptable.

ii. “should”

Indicates requirements that are not mandatory but shall be met, *if possible, within the contractual bounds*. A concerted effort should thus be made to meet these requirements, but

if not met, the system will still be deemed successful. These requirements are thus considered design goals with a strong preference.

iii. “may”

Indicates requirements that are not mandatory and should only be met with minimal development effort. If not met, the delivery will still be deemed successful. These requirements are design goals with low preference.

iv. “±”

Where the symbol “±” is used, the mathematical meaning of a symmetrical range centred at a mid-point is meant. For example, 10 mm ± 1 mm indicates a measurement parameter in the range of 9 mm to 11 mm.

4.2. Requirements

Background

The Inundu-3 airborne electronic warfare (EW) training pod houses a diverse number of subsystems that form the complete pod. One of these subsystems is the microwave (MW) Cassegrain antenna. Given that the Cassegrain antenna exhibits a marked preference for transmitting and receiving MW radiation in a specific direction (namely along its axis of circular symmetry), the antenna must be mechanically steered in order to interact with various emitters and receivers at arbitrary locations relative to the pod. It is the purpose of the *antenna positioner* to accomplish this task by mechanically adjusting the position of the antenna relative to the interior of the pod in order that radio-frequency contact may be maintained with said emitters and receivers without the necessity for the carriage aircraft to fly directly towards any specific target. This must be achieved within the confines of the pod without obstructing the operation of other subsystems, or indeed obstructing the antenna itself, all while maintaining the target weight, COG, and MOI of the Inundu-3 pod.

Figure 1 shows a cross-section of the Cassegrain antenna in the nosecone of the Inundu-3 pod a) on boresight (directed straight ahead) and b) pointed downwards at 60° off-boresight, respectively. To ensure minimum mechanical and electromagnetic (EM) interaction with the interior walls and nosecone of the pod, the diameter of the Cassegrain primary reflector (colloquially referred to as *the dish*) has been set at 340 mm diameter. It is envisaged that the antenna positioner subsystem shall attach to the rear of the Cassegrain antenna such as to permit the antenna to move as specified below in the **Coordinate System** paragraph.

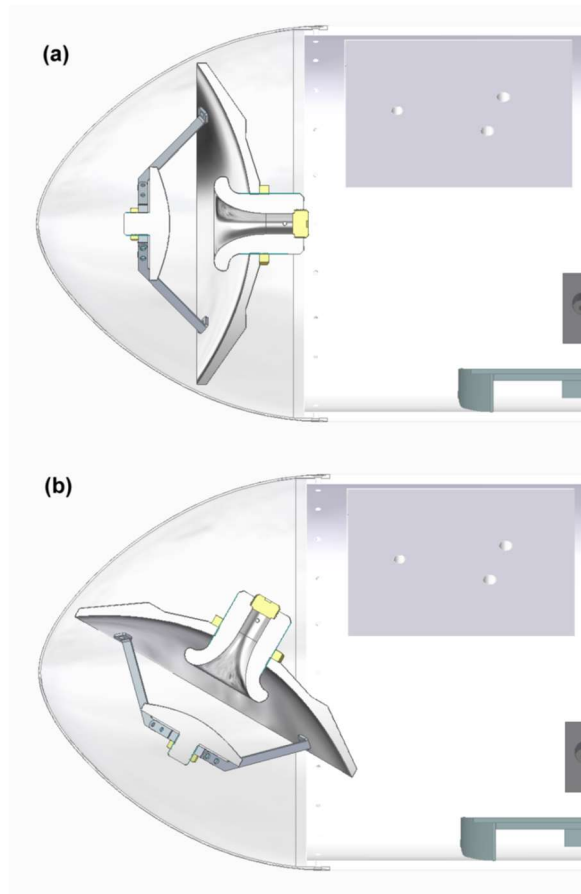

Figure 1: The Cassegrain MW Antenna located within the nosecone of the Inundu-3 airborne pod.

4.3. Antenna Positioner Requirements

Size

The antenna positioner **shall** fit inside the Inundu pod. The antenna positioner **shall** be compatible with the size, weight, and form of the proposed Cassegrain antenna. The positioner **shall** drive the position of a 340 mm diameter Cassegrain antenna located within the confines of the nosecone. The positioner **should** occupy the minimum space required to achieve the required functionality.

Weight

Cognisance **should** be given to the fact that the target weight, COG and MOI of a BL-755 cluster bomb must be achieved for the pod to be considered an equivalent payload, and thus flightworthy. Given, however, that the target weight of the pod is 262 kg \pm 8kg, it is accepted that the antenna positioner and antenna are not weight constrained. To the contrary, it is anticipated that weight will have to be *added* in strategic locations (not occupied by the antenna or antenna positioner) for the pod to be considered equivalent to a BL-755 bomb. There is thus no conceivable upper limit on the mass of the antenna positioner.

Performance

The antenna positioner **shall** steer the antenna up to 60° off-axis (off-boresight) in *any* direction (up, down, left, right, combined etc.) in response to position commands received via an RS-485 digital serial interface, as defined in **Coordinate System**. On-axis (on boresight) is defined as 0° relative to the axis of the pod, typically aligned with the z-axis of the coordinate system defined below in **Coordinate System**. Antenna position **shall** be absolute and with respect to the axes of the specified coordinate system. Direction **shall** be specified in terms of the azimuth (pan) angle, *az*, and the elevation (tilt) angle, *el*, where the resolution **shall** be equal or better than 0.25° in both azimuth and elevation. Mechanical backlash **shall** not exceed $\pm 0.25^\circ$ in any direction. The antenna positioner **shall** be able to steer the antenna at a speed of rotation of no less than 10° per second in any direction.

Mechanical Interface

The antenna positioner **shall** attach to the rear of the antenna at one or more convenient connection points on the rear of the primary reflector. Connection points **shall** not be permanent. That is to say, the antenna **shall**, for example, be disconnected from the antenna positioner during maintenance or disassembly. Suitable mechanical connections include nuts, bolts, screws, locking-pins, circlips etc. The positioner **shall not** attach to the antenna at any connection point *outside the perimeter of or in front of* the primary reflector. The antenna positioner **shall** not unduly obstruct the RF interface (coaxial cable) to the rear of the antenna.

The antenna positioner **shall** incorporate failsafe shock mounts to reduce shock and vibration to the positioner and antenna.

Electrical Interface

The positioner **should** operate from a supply of 28 VDC. The positioner **may** operate from other voltages provided by means of DC-DC converter. Power consumption **should** be kept to a minimum. The maximum power consumption **shall** be maintained below 200 W while the antenna positioner is in motion and below 20 W while the antenna is static (not in motion).

Control Interface

The antenna positioner **shall** include a control unit that receives and transmits control data via a RS-485 serial port. The controller **shall** transmit the current antenna position and status on the serial port, when polled, via the RS-485 interface.

Position Feedback

Upon wake-up the antenna positioner **shall** be able to report the antennas position. The RS-485 serial port protocol and setup **shall** be provided. Position feedback **shall** be immune to interruption, such as might occur during a power failure.

Coordinate System

The steering vector **P** shall define the direction in which the antenna is steered in terms of angles *az* (azimuth) and *el* (elevation) as shown in **Figure 2**, where the x-axis is aligned right to left of the pod, the y-axis is aligned bottom to top of the pod, and the z-axis is coaxial with the pod axis and directed out through the pod nosecone. Thus, *az* **shall** define the azimuth steering angle in the xz-plane relative to the z-axis, while *el* **shall** define the elevation steering angle, measured in a plane that contains the vector **P** and is orthogonal to the xz-plane.

Angles az and el shall both vary in the range of -60° to $+60^\circ$ such that the combined angles az and el result in the vector \mathbf{P} deviating by no more than 60° from the z-axis (the pod axis). That is to say, $\theta = \cos^{-1}(\cos(el) \times \cos(az)) \leq 60^\circ$ where θ is the angle between the vector \mathbf{P} and the z-axis, as shown in **Figure 2**.

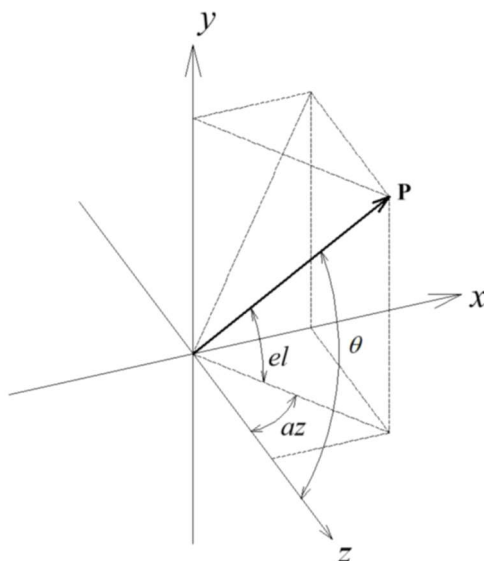

Figure 2: Coordinate system employed to define the antenna direction.

Installing and removing the positioner

It **shall** be possible to remove the antenna from the positioner from the front of the pod, by only removing the nosecone from the pod and removing the two azimuth (pan) rotating bolts. It will be required that the RF-feed to antenna need to be disconnected.

Once the antenna is removed it **shall** be possible to remove the antenna positioner from the POD. Removing the positioner **shall** be done from the front of the pod. There **shall** be a connector or connectors to enable to disconnect the antenna positioner enabling removing the antenna positioner and antenna from the pod.

It **shall** be possible to install the antenna positioner and antenna from the front of the pod, by only removing the nosecone from the pod

Other

The positioner **shall** include a “park” function to “park” the antenna to a secure position before take-off and landing. This secure position **should** ensure that the forces encountered by the antenna during take-off and landing are reduced to a minimum.

The “park” function **may** be implemented by using a break block or moving the antenna.

4.4. Positioner concept

An Az-EI positioner, such as that shown in **Figure 3**, uses motor-driven shafts and/or gears to rotate an antenna around two independent axes, the azimuth axis, and the elevation axis. With reference to **Figure 3**, the azimuth axis is oriented top to bottom, parallel to the y-axis, while the elevation axis lies in the xz-plane. Rotation about the azimuth axis causes the antenna to pan from side to side, while rotation about the elevation axis causes the antenna to tilt up or down.

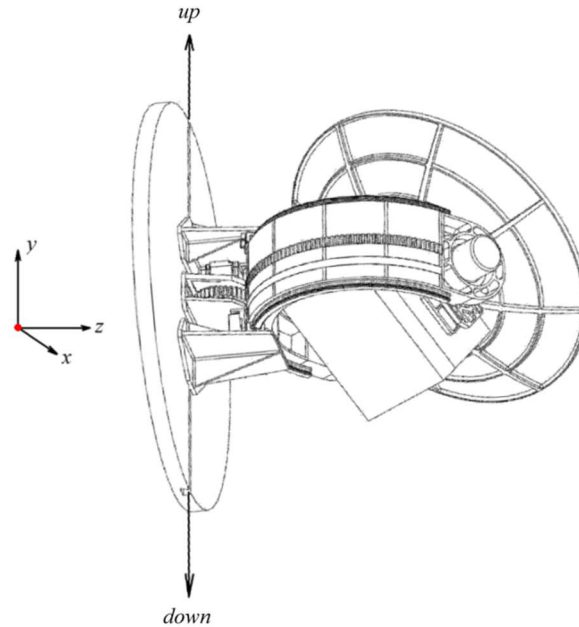

Figure 3: A vertically mounted Azimuth-Elevation antenna positioner similar to that which could be employed in the Inundu pod.

With reference to **Figure 3**, the further behind the antenna the azimuth and/or elevation axes are located, the smaller the diameter of the antenna that may be positioned within the confines of a closed space, such as the Inundu pod (whose internal diameter is ~ 400 mm). The location of the azimuth (pan) and elevation (tilt) axes must, therefore, be determined in order that the extremities of a 340mm diameter antenna not intersect the walls or nosecone of the pod.

Figure 4 shows the positioner located inside of the Inundu-3 pod, viewed through a transparent nosecone with the Cassegrain antenna adjusted to $az=45^\circ$ and $el=45$.

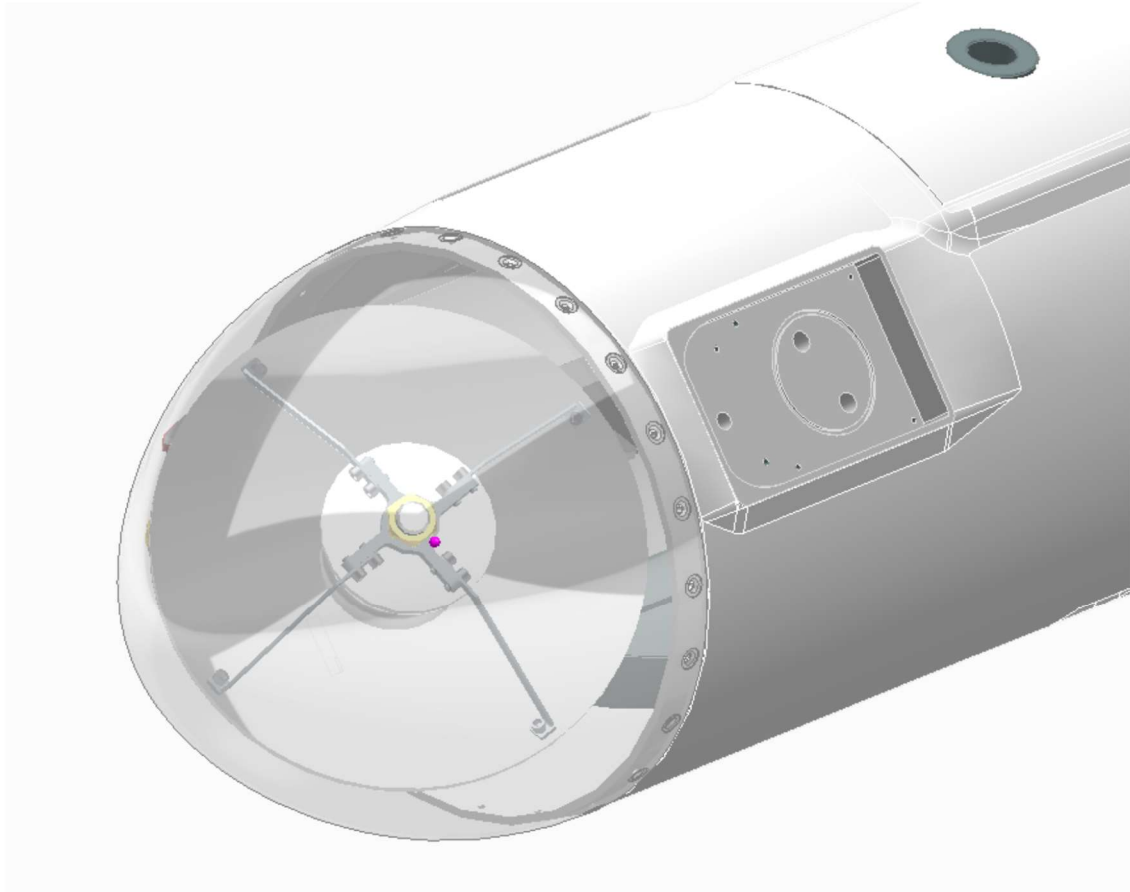

Figure 4: Azimuth-Elevation antenna positioner concept adjusted to $az=45^\circ$ and $el=45^\circ$, viewed through a transparent nosecone from in front while installed in Inundu POD.

Computer aided design (CAD) files of a proposed antenna positioner will be shared with the successful bidder.

4.5. Responsibilities

Responsibilities of bidder

The successful bidder will be responsible for the following:

- Sign and submit NDA before or at Compulsory briefing session where detail technical requirement will be discussed and current design information will be shared.
- Ensuring that ALL requirement in section 4.3 is met.
- An ATP document must be supplied to the CSIR before any other task is done. The ATP must address ALL requirement in section 4.3.

- Ensure that the proposed design is structurally secure given the weight of the antenna.
- Ensure that the proposed design is manufacturable using standard equipment.
- Adding control units to the design.
- Finalizing the provided CAD drawings.
- Creating manufacturing drawings.
- Obtaining COTS items.
- Having the custom items manufactured.
- Assembling and testing the complete positioner with the antenna supplied.
- Demonstrating the complete positioner and control system to the CSIR, fitted to the Inundu Pod housing (Pod will be supplied by CSIR and will be available to the successful bidder).
- Delivering complete data pack including BOM, CAD source files and manufacturing drawings.
- Deliver interface specification to positioner controller as well as programming files, if software is not COTS controller software.
- Delivering the complete functional positioner to the CSIR.
-

Responsibilities of CSIR

The CSIR will be responsible for the following:

- Providing all the bidders with required technical information.
- Providing the successful bidder with the following:
 - Current CAD drawing of proposed design.
 - Cad drawings of the POD's shell and nose cone.
 - Complete antenna for mechanical testing purpose.
 - Inundu Pod housing with radome.

Annexure C

Technical Evaluation Compliance Matrix/Rubrics Supply and delivery of an Antenna Positioner to the CSIR

Scoring sheet to be used to evaluate functionality

Criteria	Score description	Weighting (%)	Evidence Required
Mechanical design	<i>How will the mechanical design and forces on and in the design be verified and analysed?</i>	15	List software tools and/or relevant experience.
	Using a reputable mechanical simulation software tool. What tools are used? 100 %		
	Using previously obtained experience. Give example of experience of designs of similar complexity. 40 %		
	Actual testing of design after manufacturing. 10 %		
Mechanical manufacturing	<i>Access to manufacturing facility/tools? Provide a list of facilities available or entities to be subcontracted.</i>	10	List tools, facilities and sub-contractors (list capabilities of sub-contractor).
	Have access to all the tools and facilities to manufacture the complete positioner? 100%.		
	Have access to some of the tools and facilities to manufacture the complete positioner? 40%.		
	Does not have access to the tools and facilities to manufacture the complete positioner? 0 %.		
Experience – previous projects	<i>Examples of previous projects with Servo motors and controllers (max 100 points)</i>	40	Provide examples with high level specifications and signed reference letters on company letterhead.
	Servo motor with controller and feedback (50 % for each example with reference, max. 100 %)		
	Servo motor with controller (25 % for each example with reference, max. 50 %)		
	No examples 0%.		
Support to integrate positioner with POD's control system	<i>Is integration support included in the proposal?</i>	10	Hours included in proposal.
	Integration support is provided up to 40 hours? 100 %.		
	Integration support is provided up to 20 hours? 50 %.		
	No integration support is provided? 0 %.		
Delivery schedule for antenna positioner	5 months or less – 100%	25	Schedule of project must be provided.
	8 months or less – 70%		
	10 months or less – 50%		
	12 months or less – 40%		
	More than 12 months – 0%		
	Note : Late delivery penalty of 0.5% per week apply beyond quoted delivery delay, max. penalty 10%.		
TOTAL		100	

Annexure D

Pricing Schedule- FIRM PRICES

Supply and Delivery of Antenna Positioner to the CSIR

RFP No.1186/26/03/2025

NOTE: ONLY FIRM PRICES WILL BE ACCEPTED. NON-FIRM PRICES (INCLUDING PRICES SUBJECT TO RATES OF EXCHANGE VARIATIONS) WILL NOT BE CONSIDERED

Note: All delivery costs must be included in the bid price, for delivery at the prescribed destination.

Item No	Description	Quantity	Unit Price (VAT Excl)	Total Price (VAT Excl)
	Antenna Positioner	1		
	Delivery			
Total Price (VAT Excl)				
VAT (15%)				
Total Price (VAT Incl)				

The bidder will be responsible for the following:

- Sign and submit NDA before or at Compulsory briefing session where detail technical requirement will be discussed and current design information will be shared.
- Ensuring that ALL requirement in section 4.3 is met.
- An ATP document must be supplied to the CSIR before any other task is done. The ATP must address ALL requirement in section 4.3.
- Ensure that the proposed design is structurally secure given the weight of the antenna.
- Ensure that the proposed design is manufacturable using standard equipment.
- Adding control units to the design.
- Finalizing the provided CAD drawings.
- Creating manufacturing drawings.
- Obtaining COTS items.
- Having the custom items manufactured.
- Assembling and testing the complete positioner with the antenna supplied.
- Demonstrating the complete positioner and control system to the CSIR, fitted to the Inundu Pod housing (Pod will be supplied by CSIR and will be available to the successful bidder).
- Delivering complete data pack including BOM, CAD source files and manufacturing drawings.
- Deliver interface specification to positioner controller as well as programming files, if software is not COTS controller software.
- Delivering the complete functional positioner to the CSIR.
- Delivery address: Council for Scientific and Industrial Research (CSIR)Meiring Naudé Rd, Brummeria, Pretoria, 0184

Annexure E

Proposal Form and List of Returnable Documents

Supply and Delivery of an Antenna Positioner

RFP No.1186/26/03/2025

I/We _____

[name of entity, company, close corporation or partnership] of [full address]

carrying on business trading/operating as

represented by _____ in my capacity
as

being duly authorised thereto by a Resolution of the Board of Directors or Members or Certificate of Partners, dated _____ to enter into, sign execute and complete any documents relating to this proposal and any subsequent Agreement. The following list of persons are hereby authorised to negotiate on behalf of the abovementioned entity, should CSIR decide to enter into Post Tender Negotiations with shortlisted bidder(s).

FULL NAME(S) CAPACITY SIGNATURE

I/We hereby offer to supply the above mentioned Services at the prices quoted in the schedule of prices in accordance with the terms set forth in the documents listed in the accompanying schedule of RFP documents.

I/We agree to be bound by those conditions in CSIR's:

1. General RFP Terms and Conditions; and [CSIR's Purchasing Terms and Conditions](#) or Any other standard or special conditions mentioned and/or embodied in this Request for Proposal.

I/We accept that unless CSIR should otherwise decide and so inform me/us in writing of award/intent, this Proposal [and, if any, its covering letter and any subsequent exchange of correspondence], together with CSIR's acceptance thereof shall constitute a binding contract between CSIR and me/us.

I/We further agree that if, after I/we have been notified of the acceptance of my/our Proposal, I/we fail to enter into a formal contract if called upon to do so, or fail to commence the supply of Services within 4 [four] weeks thereafter, CSIR may, without prejudice to any other legal remedy which it may have, recover from me/us any expense to which it may have been put in calling for Proposals afresh and/or having to accept any less favourable Proposal.

I/We accept that any contract resulting from this offer will be for a period as determined by the CSIR.

Furthermore, I/we agree to a penalty clause/s which will allow CSIR to invoke a penalty against us for non-compliance with material terms of this RFP including the delayed delivery of the Services due to non-performance by ourselves, failure to meet Subcontracting.

I/we agree that non-compliance with any of the material terms of this RFP, including those mentioned above, will constitute a material breach of contract and provide CSIR with cause for cancellation.

ADDRESS FOR NOTICES

The law of the Republic of South Africa shall govern any contract created by the acceptance of this RFP. The domicilium citandi et executandi shall be a place in the Republic of South Africa to be specified by the Respondent hereunder, at which all legal documents may be served on the Respondent who shall agree to submit to the jurisdiction of the courts of the Republic of South Africa. Foreign Respondents shall, therefore, state hereunder the name of their authorised representative in the Republic of South Africa who has the power of attorney to sign any contract which may have to be entered into in the event of their Proposal being accepted and to act on their behalf in all matters relating to such contract.

Respondent to indicate the details of its domicilium citandi et executandi hereunder:

Name of Entity:

Facsimile: _____

Address: _____

NOTIFICATION OF AWARD OF RFP

As soon as possible after approval to award the contract(s), the successful Respondent [**the Service provider**] will be informed of the acceptance of its Proposal. Unsuccessful Respondents may be advised in writing of the name of the successful Service provider and the reason as to why their Proposals have been unsuccessful, for example, in the category of price, delivery period, quality, B-BBEE or for any other reason.

VALIDITY PERIOD

CSIR requires a validity period of 90 [Ninety calendar Days from closing date] against this RFP.

Bidders are to note that they may be requested to extend the validity period of their bid, at the same terms and conditions, if the internal evaluation process has not been finalised within the validity period. However, once the adjudication body has approved the process and award of the business to the successful bidder(s), the validity of the successful bidder(s)' bid will be deemed to remain valid until a final contract has been concluded.

NAME(S) AND ADDRESS / ADDRESSES OF DIRECTOR(S) OR MEMBER(S)

The Respondent must disclose hereunder the full name(s) and address(s) of the director(s) or members of the company or close corporation [C.C.] on whose behalf the RFP is submitted.

- 1. Registration number of company / C.C.

- 2. Registered name of company / C.C.

- 3. Full name(s) of director/member(s) Address/Addresses ID Number(s)

RETURNABLE DOCUMENTS

Returnable Documents means all the documents, Sections and Annexures, as listed in the tables below.

a) **Mandatory Returnable Documents**

Failure to provide any Mandatory Returnable Documents at the closing date and time of this bid will result in a Respondent’s disqualification. Bidders are therefore urged to ensure that all these documents are returned with their Proposals.

Please confirm submission of the mandatory Returnable Documents detailed below by so indicating [**Yes** or **No**] in the table below:

MANDATORY RETURNABLE DOCUMENTS	SUBMITTED [Yes/No]
In the case of Joint Ventures, bidder must submit a copy of the <u>signed</u> Joint Venture Agreement.	
In the case of subcontracting arrangements, bidder must submit a copy of the <u>signed</u> subcontracting agreement.	
Annexure J: Mutual Non-Disclosure Agreement	

b) **Essential Returnable Documents**

In addition to the requirements of section (a) above, Respondents are further required to submit with their Proposals the following **essential Returnable Documents** as detailed below.

Essential Returnable Documents required for evaluation purposes:

Failure to provide any essential Returnable Documents used for purposes of scoring a bid, by the closing date and time of this bid will not result in a Respondent’s disqualification. However, Bidders will receive an automatic score of zero for the applicable evaluation criterion. Bidders are therefore urged to ensure that all these documents are returned with their Proposals.

Please confirm submission of these essential Returnable Documents by so indicating [Yes or No] in the table below:

ESSENTIAL RETURNABLE DOCUMENTS USED FOR SCORING	SUBMITTED
Annexure C: Pricing Schedule or Bill of Quantities	

<p>Annexure H: Preference Points Award Form in Terms of the Preferential Procurement Regulations 2022 (Mandatory documents to claim preference points)</p> <ul style="list-style-type: none"> • Valid copy of BBEE certificate/ sworn affidavit <ul style="list-style-type: none"> ✓ In case of unincorporated trust, consortium or joint venture, they must submit their consolidated B-BBEE scorecard with their <u>individual B-BBEE Certificate or Sworn Affidavit</u>. ✓ In case of sub-contracting both parties must submit copies of their valid BBEE certificates. <p>NB: Non-submission or invalid submission will result in zero points. Should the individual entity's B-BBEE Certificate or Sworn Affidavit of the unincorporated trust, consortium or joint venture parties <u>be invalid</u>, the joint venture scorecard will also be invalid.</p>	
Detailed Technical Proposal	
Compliance Matrix for Required Services	
Document with Company Profile detailing capability and experience	

Other Essential Returnable Documents:

Failure to provide other essential Returnable Documents may result in a Respondent's disqualification. Bidders are therefore urged to ensure that all these documents are returned with their Proposals.

Please confirm submission of these essential Returnable Documents by indicating Yes or No in the table below

<u>OTHER ESSENTIAL RETURNABLE DOCUMENTS</u>	SUBMITTED [Yes/No]
Annexure A: Standard Bidding Document (SBD) 1 Form	
Annexure E: Proposal Form and List of Returnable documents <i>(This document)</i>	
Annexure F: Certificate of Acquaintance with RFP, Terms & Conditions & Applicable Documents	
Annexure H: Standard Bidding Document (SBD) 4 Form	
Annexure I: RFP Declaration and Breach of Law Form	

CONTINUED VALIDITY OF RETURNABLE DOCUMENTS

The successful Respondent will be required to ensure the validity of all returnable documents, including but not limited to its Tax Clearance Certificate and valid B-BBEE Verification Certificate, for the duration of any contract emanating from this RFP. Should the Respondent be awarded the contract **[the Agreement]** and fail to present CSIR with such renewals as and when they become due, CSIR shall be entitled, in addition to any other rights and remedies that it may have in terms of the eventual Agreement, to terminate such Agreement forthwith without any liability and without prejudice to any claims which CSIR may have for damages against the Respondent.

SIGNED at _____ on this _____ day of _____ 20_____

SIGNATURE OF WITNESSES AND NAME OF WITNESSES

1 _____

Name _____

2 _____

Name _____

SIGNATURE OF RESPONDENT'S AUTHORISED REPRESENTATIVE:

Name: _____

Designation: _____

Annexure F

Certificate of Acquaintance with RFP, Terms & Conditions & Applicable Documents

By signing this certificate the Respondent is deemed to acknowledge that he/she has made himself/herself thoroughly familiar with, and agrees with all the conditions governing this RFP. This includes those terms and conditions contained in any printed form stated to form part hereof, including but not limited to the documents stated below. As such, CSIR will recognise no claim for relief based on an allegation that the Respondent overlooked any such condition or failed properly to take it into account for the purpose of calculating tendered prices or any other purpose:

Should the Bidder find any terms or conditions stipulated in any of the relevant documents quoted in the RFP unacceptable, it should indicate which conditions are unacceptable and offer alternatives by written submission on its company letterhead, attached to its submitted Bid. Any such submission shall be subject to review by CSIR's Legal Counsel who shall determine whether the proposed alternative(s) are acceptable or otherwise, as the case may be. A material deviation from any term or condition may result in disqualification.

Bidders accept that an obligation rests on them to clarify any uncertainties regarding any bid which they intend to respond on, before submitting the bid. The Bidder agrees that he/she will have no claim based on an allegation that any aspect of this RFP was unclear but in respect of which he/she failed to obtain clarity.

The bidder understands that his/her Bid will be disqualified if the Certificate of Acquaintance with RFP documents included in the RFP as a returnable document, is found not to be true and complete in every respect.

SIGNED at _____ on this _____ day of _____ 20_____

SIGNATURE OF WITNESSES AND NAME OF WITNESSES

1 _____

Name _____

2 _____

Name _____

SIGNATURE OF RESPONDENT'S AUTHORISED REPRESENTATIVE:

Name: _____

Designation: _____

Annexure G

Preference Points Award Form in Terms of the Preferential Procurement Regulations 2022

This preference form must form part of all bid. It contains general information and serves as a claim form for the preference points allocated on the basis of specific goals outlined in point 3 below.

NB: BEFORE COMPLETING THIS FORM, BIDDERS MUST STUDY THE GENERAL CONDITIONS, DEFINITIONS AND DIRECTIVES APPLICABLE IN RESPECT OF SPECIFIC GOALS, AS PRESCRIBED IN THE PREFERENTIAL PROCUREMENT REGULATIONS, 2022

1. GENERAL CONDITIONS

- 1.1 The following preference point systems are applicable to this bid:
- the 80/20 system for requirements with a Rand value of up to R50 000 000 (all applicable taxes included).
- 1.2 Points for this bid shall be awarded for:
- (a) Price; and
 - (b) Preference Points based on specific goals.
- 1.3 The maximum points for this bid are allocated as follows:

	POINTS
PRICE	80
Preference Points	20
Total points for Price and Preference Points must not exceed	100

- 1.4 Failure on the part of a bidder to submit proof of preference points together with the bid, will be interpreted to mean that preference points are not claimed.
- 1.5 The CSIR reserves the right to require of a bidder, either before a bid is adjudicated or at any time subsequently, to substantiate any claim in regard to preferences, in any manner required by the CSIR.

2. POINTS AWARDED FOR PRICE

2.1 The 80/20 preference points systems

A maximum of 80 points is allocated for price on the following basis:

80/20

$$P_s = 80 \left(1 - \frac{P_t - P_{\min}}{P_{\min}} \right)$$

Where

P_s = Points scored for price of bid under consideration

P_t = Price of bid under consideration

P_{\min} = Price of lowest acceptable bid

3. PREFERENCE POINTS AWARDED

3.1 In terms of Regulation 4 (2) and 4 (2) of the Preferential Procurement Regulations, preference points may be awarded to a bidder for the specific goal specified for the tender in accordance with the table below:

3.2 Specific goals must be determined per tender.

Specific Goals	Preference Points
Black Ownership	20
Total	20

3.3 Total preference points per specific goal to be determined per tender.

3.3.1. Total preference points per specific goal to be awarded as follows:

3.3.1.1. Preferential points for black ownership will be awarded as follows:

Black Ownership	% of Preferential points
Bidder with 100% black ownership	100%
Bidder with 51% to 99% black ownership	50%
Bidder with less than 51% black ownership	0%

3.4. Joint Ventures, Consortiums and Trusts

A trust, consortium or joint venture¹ will qualify for preference points as a legal entity (Incorporated), provided that the entity submits its valid B-BBEE certificate. Only valid BBEE certificates issued by SANAS accredited verification agency will be considered for allocation of points.

A trust, consortium or joint venture will qualify for preference points as an unincorporated entity, provided that the entity submits their consolidated B-BBEE scorecard as if they were a group structure and that such a consolidated B-BBEE scorecard is prepared for every

¹ Joint venture or Consortium means an association of persons for the purpose of combining their expertise, property, capital, efforts, skill and knowledge in an activity for the execution of a contract.

separate bid. Only valid consolidated BBEE certificates issued by SANAS accredited verification agency will be considered for allocation of points.

Bidders must submit concrete proof of the existence of joint ventures and/or consortium arrangements. The CSIR will accept signed agreements as acceptable proof of the existence of a joint venture and/or consortium arrangement. Furthermore, in bids where unincorporated joint venture and/or consortium/sub-contractors are involved, each party must submit a separate TCS PIN and CSD number.

The joint venture and/or consortium agreements must clearly set out the roles and responsibilities of the Lead Partner and the joint venture and/or consortium party. The agreement must also clearly identify the Lead Partner, who shall be given the power of attorney to bind the other party/parties in respect of matters pertaining to the joint venture and/or consortium arrangement.

3.5. Sub-contracting

A bidder must not be awarded preference points if it is indicated in the tender documents that such a bidder intends sub- contracting more than 25% of the value of the contract to any other enterprise that does not qualify for at least the points that such a bidder qualifies for, unless the intended sub-contractor is an EME that has the capability and ability to execute the sub-contract.

A bidder awarded a contract may not sub-contract more than 25% of the value of the contract to any other enterprise that does not have an equal or higher B-BBEE status level than the bidder concerned, unless the contract is sub-contracted to an EME that has the capability and ability to execute the sub-contract.

4. BID DECLARATION

Bidders who claim points in respect of specific goals **must** submit the following documents:

Mandatory documents to claim preference points	Submitted	
	Yes √	No √
Valid copy of BBEE certificate/ sworn affidavit to claim Black Ownership preference points ²		

DECLARATION WITH REGARD TO COMPANY/FIRM

Name of company/firm:.....

VAT registration number:.....

Company registration number:.....

² In case of unincorporated trust, consortium or joint venture, they must submit their consolidated B-BBEE scorecard with submitting their **individual B-BBEE Certificate or Sworn Affidavit**, and each party must submit a separate TCS PIN and CSD number.
In case of sub-contracting both parties must submit copies of their valid BBEE certificates

I/we, the undersigned, who is / are duly authorised to do so on behalf of the company/firm, certify that the documents submitted to claim preference points based on the specific goals are valid, and I / we acknowledge that:

- i) The information furnished is true and correct;
- ii) The preference points claimed are in accordance with the General Conditions as indicated in paragraph 3 of this form;
- iii) In the event of a contract being awarded as a result of points claimed as shown in paragraphs 3, the contractor may be required to furnish further documentary proof to the satisfaction of the CSIR that the awarded are correct;
- iv) If any document is obtained on a fraudulent basis or any of the conditions of contract have not been fulfilled, the CSIR may, in addition to any other remedy it may have –
 - (a) disqualify the person from the bidding process;
 - (b) recover costs, losses or damages it has incurred or suffered as a result of that person's conduct;
 - (c) cancel the contract and claim any damages which it has suffered as a result of having to make less favourable arrangements due to such cancellation;
- (d) recommend that the bidder or contractor, its shareholders and directors, or only the shareholders and directors who acted on a fraudulent basis, be restricted by the National Treasury from obtaining business from any organ of state for a period not exceeding 10 years, after the *audi alteram partem* (hear the other side) rule has been applied; and
- (e) forward the matter for criminal prosecution.
- v) If the CSIR is of the view that a bidder submitted false information regarding a specific goal, it must—
 - (a) inform the bidder accordingly; and
 - (b) give the bidder an opportunity to make representations within 14 days as to why the tender may not be disqualified or, if the tender has already been awarded to the bidder, the contract should not be terminated in whole or in part.
- vi) After considering the representations referred to in subregulation (v)(b), the CSIR may, if it concludes that such information is false—
 - (a) disqualify the bidder or terminate the contract in whole or in part; and
 - (b) if applicable, claim damages from the bidder.

WITNESSES
1.
2.

..... SIGNATURE(S) OF BIDDERS(S)
DATE:
ADDRESS.....

Annexure H

Standard Bidding Document (SBD) 4

BIDDER'S DISCLOSURE

1. PURPOSE OF THE FORM

Any person (natural or juristic) may make an offer or offers in terms of this invitation to bid. In line with the principles of transparency, accountability, impartiality, and ethics as enshrined in the Constitution of the Republic of South Africa and further expressed in various pieces of legislation, it is required for the bidder to make this declaration in respect of the details required hereunder.

Where a person/s are listed in the Register for Tender Defaulters and / or the List of Restricted Suppliers, that person will automatically be disqualified from the bid process.

2. Bidder's declaration

2.1 Is the bidder, or any of its directors / trustees / shareholders / members / partners or any person having a controlling interest³ in the enterprise, employed by the state? YES / NO

2.1.1 If so, furnish particulars of the names, individual identity numbers, and, if applicable, state employee numbers of sole proprietor/ directors / trustees / shareholders / members/ partners or any person having a controlling interest in the enterprise, in table below.

Full Name	Identity Number	Name of State institution

2.2 Do you, or any person connected with the bidder, have a relationship with any person who is employed by the procuring institution? YES / NO

2.2.1 If so, furnish particulars:

³ the power, by one person or a group of persons holding the majority of the equity of an enterprise, alternatively, the person/s having the deciding vote or power to influence or to direct the course and decisions of the enterprise.

.....
.....

2.3 Does the bidder or any of its directors / trustees / shareholders / members / partners or any person having a controlling interest in the enterprise have any interest in any other related enterprise whether or not they are bidding for this contract? YES / NO

2.3.1 If so, furnish particulars:

.....
.....

3 DECLARATION

I, the undersigned, (name).....in submitting the accompanying bid, do hereby make the following statements that I certify to be true and complete in every respect:

- 3.1 I have read and I understand the contents of this disclosure;
- 3.2 I understand that the accompanying bid will be disqualified if this disclosure is found not to be true and complete in every respect;
- 3.3 The bidder has arrived at the accompanying bid independently from, and without consultation, communication, agreement or arrangement with any competitor. However, communication between partners in a joint venture or consortium⁴ will not be construed as collusive bidding.
- 3.4 In addition, there have been no consultations, communications, agreements or arrangements with any competitor regarding the quality, quantity, specifications, prices, including methods, factors or formulas used to calculate prices, market allocation, the intention or decision to submit or not to submit the bid, bidding with the intention not to win the bid and conditions or delivery particulars of the products or services to which this bid invitation relates.
- 3.4 The terms of the accompanying bid have not been, and will not be, disclosed by the bidder, directly or indirectly, to any competitor, prior to the date and time of the official bid opening or of the awarding of the contract.
- 3.5 There have been no consultations, communications, agreements or arrangements made by the bidder with any official of the procuring institution in relation to this procurement process prior to and during the bidding process except to provide clarification on the bid submitted where so required by the institution; and the bidder was not involved in the drafting of the specifications or terms of reference for this bid.
- 3.6 I am aware that, in addition and without prejudice to any other remedy provided to combat any restrictive practices related to bids and contracts, bids that are suspicious will be reported to the Competition Commission for investigation and possible imposition of administrative penalties in terms of section 59 of the Competition Act No 89 of 1998 and or may be reported to the National Prosecuting Authority (NPA) for criminal investigation and or may be restricted from conducting business with the public sector for a period not exceeding ten (10) years in terms of the Prevention and Combating of Corrupt Activities

⁴ Joint venture or Consortium means an association of persons for the purpose of combining their expertise, property, capital, efforts, skill and knowledge in an activity for the execution of a contract.

Act No 12 of 2004 or any other applicable legislation.

I CERTIFY THAT THE INFORMATION FURNISHED IN PARAGRAPHS 1, 2 and 3 ABOVE IS CORRECT.

I ACCEPT THAT THE STATE MAY REJECT THE BID OR ACT AGAINST ME IN TERMS OF PARAGRAPH 6 OF PFMA SCM INSTRUCTION 03 OF 2021/22 ON PREVENTING AND COMBATING ABUSE IN THE SUPPLY CHAIN MANAGEMENT SYSTEM SHOULD THIS DECLARATION PROVE TO BE FALSE.

.....
Signature

.....
Date

.....
Position

.....
Name of bidder

Annexure I

DECLARATION BY BIDDER AND BREACH OF LAW FORM

NAME OF ENTITY:

We _____ do hereby certify that:

1. CSIR has supplied and we have received appropriate responses to any/all questions [as applicable] which were submitted by ourselves for RFP Clarification purposes;
2. we have received all information we deemed necessary for the completion of this Request for Proposal [**RFP**];
3. we have been provided with sufficient access to the existing CSIR facilities/sites and any and all relevant information relevant to the Services as well as CSIR information and Employees, and has had sufficient time in which to conduct and perform a thorough due diligence of CSIR's operations and business requirements and assets used by CSIR. CSIR will therefore not consider or permit any pre- or post-contract verification or any related adjustment to pricing, service levels or any other provisions/conditions based on any incorrect assumptions made by the Respondent in arriving at his Bid Price.
4. at no stage have we received additional information relating to the subject matter of this RFP from CSIR sources, other than information formally received from the designated CSIR contact(s) as nominated in the RFP documents;
5. we are satisfied, insofar as our entity is concerned, that the processes and procedures adopted by CSIR in issuing this RFP and the requirements requested from Bidders in responding to this RFP have been conducted in a fair and transparent manner; and
6. furthermore, we declare that a family, business and/or social relationship **exists / does not exist** [delete as applicable] between an owner / member / director / partner / shareholder of our entity and an employee or board member of the CSIR Group including any person who may be involved in the evaluation and/or adjudication of this Bid.
7. In addition, we declare that an owner / member / director / partner / shareholder of our entity **is / is not** [delete as applicable] an employee or board member of the CSIR.
8. If such a relationship as indicated in paragraph 7 exists, the Respondent is to complete the following section:

FULL NAME OF OWNER/MEMBER/DIRECTOR/
PARTNER/SHAREHOLDER: ADDRESS:

Indicate nature of relationship with CSIR:

[Failure to furnish complete and accurate information in this regard may lead to the disqualification of a response and may preclude a Respondent from doing future business with CSIR]

9. We declare, to the extent that we are aware or become aware of any relationship between ourselves and CSIR [other than any existing and appropriate business relationship with CSIR] which could unfairly advantage our entity in the forthcoming adjudication process, we shall notify CSIR immediately in writing of such circumstances.
10. We accept that any dispute pertaining to this Bid will be resolved through the Ombudsman process and will be subject to the Terms of Reference of the Ombudsman. The Ombudsman process must first be exhausted before judicial review of a decision is sought.
11. We further accept that CSIR reserves the right to reverse an award of business or decision based on the recommendations of the Ombudsman without having to follow a formal court process to have such award or decision set aside.

BREACH OF LAW

12. We further hereby certify that I/we (the bidding entity and/or any of its directors, members or partners) have/have not been [delete as applicable] found guilty during the preceding 5 [five] years of a serious breach of law, including but not limited to a breach of the Competition Act, 89 of 1998, by a court of law, tribunal or other administrative body. The type of breach that the Respondent is required to disclose excludes relatively minor offences or misdemeanours, e.g. traffic offences. This includes the imposition of an administrative fine or penalty.

Where found guilty of such a serious breach, please disclose:

NATURE OF BREACH:

DATE OF BREACH: _____

Furthermore, I/we acknowledge that CSIR reserves the right to exclude any Respondent from the bidding process, should that person or entity have been found guilty of a serious breach of law, tribunal or regulatory obligation.

SIGNED at _____ on this _____ day of _____
20____

For and on behalf of _____ duly authorised hereto	AS WITNESS:
Name:	Name:

Position:	Position:
Signature:	Signature:
Date	Registration No of Company/CC
Place	Registration Name of Company/CC

Annexure J

Mutual Non-Disclosure Agreement

RFP No.1186/26/03/2025

MUTUAL NON-DISCLOSURE AGREEMENT

1. Preamble

The Parties as identified herein are engaged in discussions relating to their potential collaboration in the Field as likewise described therein; are by virtue thereof are required to disclose Confidential Information to one another, and have agreed to do so subject to the terms and conditions as set out in this agreement.

2. Definitions

- 2.1. The following words and/or phrases, when used in this agreement, shall have the following meanings:
- 2.1.1. “Confidential Information” shall mean all scientific, technical, business, financial, past, present or future research, development, business activities, products, services and technical knowledge or marketing information , whether inside or outside the Field, which one party (the “Disclosing Party”) discloses to the other party (the “Receiving Party”) in connection with the discussions, and either has been identified in writing as confidential or is of such a nature (or has been disclosed in such a way) that it should be obvious to the Receiving Party that it constitutes Confidential Information. (Without limiting the generality of the foregoing, “Confidential Information” shall include any information that falls within the definition of ‘Personal Information’
- 2.1.2. “Disclosing Party” shall mean the Party disclosing Confidential Information under this agreement;
- 2.1.3. “Disclosing Purpose” shall mean, as pertains to any particular joint opportunity(ies) in the Field, the discussions held or to be held between the Parties regarding their possible collaboration and future working relationship with regards to any such opportunity(ies);
- 2.1.4. “Effective Date’ shall mean the date of the commencement of this agreement which would be a bid award date”;
- 2.1.5. “Notice” shall mean a written document addressed by one Party to the other and either delivered by hand; sent per registered post or telefaxed to the addresses as indicated herein”;
- 2.1.6. “Personal Information” means any information that falls within the definition of ‘Personal Information’ as defined in the Protection of Personal Information Act, No 4 of 2013 (“POPI”);
- 2.1.7. “Receiving Party” shall mean the Party receiving Confidential Information under this agreement;

“Responsible Party” means a public or private body or any other person which, alone or in conjunction with others, determines the purpose of and means for processing personal information, as defined in POPI.

3. Obligation of Confidentiality

- 3.1. The Receiving Party undertakes and agrees:
- 3.1.1. to use the Disclosing Party’s Confidential Information only to give effect to the Disclosing Purpose;
- 3.1.2. to hold in strict confidence and not to publish or disclose to any unauthorised third parties any of the Confidential Information of the Disclosing Party without the prior written consent of the Disclosing Party;
- 3.1.3. to use the same degree of care (and in any event not less than reasonable care) to safeguard the confidentiality of the Disclosing Party’s Confidential Information that it uses to protect its own information of like kind;
- 3.1.4. to limit any disclosure of such Confidential Information only to those of its employees and professional advisors who have a specific need –to- know to access such Confidential Information and either entered into a written agreement which impose, or are otherwise bound by the same restrictions as those imposed upon it by virtue of this agreement;
- 3.1.5. not to disclose or reveal to any third party, whomsoever, either the fact that discussions or negotiations are taking, or have taken, place between the Parties; the content of any such discussions, or other facts relating to the Disclosing Purpose;
- 3.1.6. on termination of this agreement, to act with the Disclosing Party’s Confidential Information in accordance with a Notice delivered to it by the Disclosing Party, and if no such Notice is delivered to the Recipient, to destroy the Disclosing Party’s Confidential Information in a similar manner to which it would destroy its own Confidential Information.

4. Protection of Personal Information

- 4.1. The Party(ies) undertake(s) to:-
- 4.1.1. comply with the provisions of POPI as well as all applicable legislation as amended or substituted from time to time;
- 4.1.2. treat all Personal Information strictly as defined within the parameters of POPI;
- 4.1.3. process Personal Information only in accordance with the consent it was obtained for, for the purpose agreed, any lawful and

reasonable written instructions received from the applicable Responsible Party and as permitted by law;

- 4.1.4. process Personal Information in compliance with the requirements of all applicable laws;
 - 4.1.5. secure the integrity and confidentiality of any Personal Information in its possession or under its control by taking appropriate, reasonable technical and organisational measures to prevent loss, damage, unauthorised destruction, access, use, disclosure or any other unlawful processing of Personal Information;
 - 4.1.6. not transfer any Personal Information to any third party in a foreign country unless such transfer complies with the relevant provisions of POPI regarding transborder information flows; and
 - 4.1.7. not retain any Personal Information for longer than is necessary for achieving the purpose in terms of this Agreement or in fulfilment of any other lawful requirement.
- 4.2. The Party(ies) undertake(s) to ensure that all reasonable measures are taken to:
- 4.2.1. identify reasonably foreseeable internal and external risks to the Personal Information in its possession or under its control;
 - 4.2.2. establish and maintain appropriate security safeguards against the identified risks;
 - 4.2.3. regularly verify that the security safeguards are effectively implemented;
 - 4.2.4. ensure that the security safeguards are continually updated in response to new risks or deficiencies in previously implemented safeguards;
 - 4.2.5. provide immediate notification to the Responsible Party if a breach in information security or any other applicable security safeguard occurs; provide immediate notification to the Responsible Party where there are reasonable grounds to believe that the Personal Information has been accessed or acquired by any unauthorised person;
 - 4.2.6. remedy any breach of a security safeguard in the shortest reasonable time and provide the Responsible Party with the details of the breach and, if applicable, the reasonable measures implemented to address the security safeguard breach;
 - 4.2.7. provide immediate notification to the Responsible Party where either party has, or reasonably suspects that, Personal Information has been processed outside of the purpose agreed to or consented to;
 - 4.2.8. provide the Responsible Party, upon request, with all information of any nature whatsoever relating to the processing of the Personal Information for the purpose in terms of this Agreement and any applicable law; and

- 4.2.9. notify the CSIR, if lawful, of receipt of any request for access to Personal Information, in its possession and relating to the CSIR.
- 4.3. The CSIR reserves the right to inspect the Personal Information processing operations, as well as the technical and organisational information security measures employed by the contracting Party to ensure compliance with the provisions of clause 4.
- 4.4. The provisions of clause 4 shall survive the termination of this Agreement, regardless of cause, in perpetuity.

5. Exclusions

- 5.1. The Receiving Party recognises that this agreement is not intended to restrict use or disclosure of any portion of the Disclosing Party's Confidential Information which:
- 5.1.1. is as at the Effective Date, or later, made known to the public or otherwise enters the public domain through no default by the Receiving Party of its obligations under this Agreement;
 - 5.1.2. it can show was in its possession prior to the earliest disclosure by the Disclosing Party, as evidenced by written documents in its files;
 - 5.1.3. is rightfully received by it from a third party having no obligation of confidentiality to the Disclosing Party;
 - 5.1.4. is independently developed by the Receiving Party by a person(s) who did not have access to the Confidential Information of the Disclosing Party;
 - 5.1.5. is disclosed by the Receiving Party after receipt of written permission from the Disclosing Party; or
 - 5.1.6. it is requested or required by subpoena, court order, or similar process to disclose, provided that, in such an event, it will provide the Disclosing Party with prompt written notice of such request(s) so that the latter may seek an appropriate protective order and/or waive the Receiving Party's compliance with the provisions of this agreement.

6. Ownership and Provision of Information

- 6.1. The Disclosing Party shall retain ownership of all its Confidential Information as disclosed hereunder.
- 6.2. Nothing contained in this agreement or in any disclosures made hereunder shall create or imply, or be construed as to grant to the Receiving Party any license or other rights in or to the Confidential Information and/or any intellectual property rights attached thereto, or act as a waiver of any rights that the Disclosing Party may have to prevent infringement or misappropriation of any patents, patent applications, trademarks, copyright, trade secrets, know-how or other intellectual property

rights owned or controlled by the Disclosing Party as at the Effective Date.

- 6.3. The Disclosing Party provides the Confidential Information "as is" and accordingly no disclosure thereof by it hereunder shall constitute any representation, warranty, assurance, guarantee or inducement by such Disclosing Party with respect to infringement of patents or other rights of third parties, nor is any warranty or representation as to the accuracy, completeness, or technical or scientific quality of any of the Disclosing Party's Confidential Information provided hereunder. (For the avoidance of doubt it is stated expressly that the Disclosing Party neither makes, nor have made, any representation or warranty as to the merchantability or fitness for a particular purpose of any Confidential Information disclosed hereunder).

7. Term of Obligation

- 7.1. The Parties' obligations concerning non-disclosure of Confidential Information contained in the above clauses shall commence on the Effective Date and shall continue for five (5) years from the date of each disclosure, unless otherwise agreed between the parties in writing, where after such obligations shall forthwith terminate.

8. No Violation

- 8.1. Each party represents that its compliance with the provisions of this agreement will not violate any duty which such party may have towards any third party, including obligations concerning the provision of services to others, confidentiality of information and assignment of inventions, ideas, patents or copyright.

9. Breach

- 9.1. It is acknowledged that the breach of this agreement by the Receiving Party would cause the Disclosing Party irreparable injury not compensable in monetary damages alone. Accordingly, in the event of a breach, or a threat of a breach, the Disclosing Party, in addition to its other remedies, is entitled to a restraining order, preliminary injunction or similar relief so as to specifically enforce the terms of this agreement or prevent, cure or reduce the adverse effects of the breach.

10. DOMICILIUM CITANDI ET EXECUTANDI

- 10.1. The Parties hereto respectively choose as their *domicilium citandi et executandi* for all purposes of, and in connection with this agreement, the physical addresses and contact details stated herein.

11. Notices

- 11.1 Any Notice to be given hereunder shall be given in writing and may be given either personally or may be sent by post or facsimile and addressed to the relevant party at its *domicilium citandi et executandi* address as chosen herein. Any notice given by post shall be deemed to have been served on the expiry of 7 (seven) working days after same is posted by recorded delivery post or air mail. Any notice delivered personally or sent by facsimile shall be deemed to have been served at the time of delivery or sending.

12. Governing Law and Jurisdiction

- 12.1. This agreement will be governed and construed by the laws of the Republic of South Africa and the Parties hereby submit to the exclusive jurisdiction of the South African courts to hear any dispute arising therefrom which the Parties are unable to settle amicably.

13. General

- 13.1. This agreement comprises the entire agreement between the parties concerning the subject matter and supersedes all prior oral and written agreements between them.
- 13.2. No waiver, alteration or cancellation of any of the provisions of the Agreement shall be binding unless made in writing and signed by the party to be bound.
- 13.3. The parties hereby warrant that the officials signing this agreement have the power to do so on behalf of the parties.
- 13.4. No public announcement, such as a media release, or disclosure beyond those disclosures authorised for Confidential Information hereunder may be made by either party concerning this agreement without the prior written approval of the other party.
- 13.5. Neither party is, by virtue of this agreement, authorised to use the name, logo(s) or trademarks of the other in connection with any advertising, publicity, marketing or promotional materials or activities, or for any other purpose whatsoever, without the prior written consent of the other party. For purposes of this clause, it is also recognised that, under the provisions of section 15 (1) of the Merchandise Marks Act, Act No 17 of 1941 of the Republic of South Africa, the use of the abbreviation of the name of the Council for Scientific and Industrial Research, "WNNR" and CSIR, is prohibited in connection with any trade, business, profession or occupation or in connection with a trade mark, mark or trade description applied to goods, other than with the consent of the CSIR.
- 13.6. Both Parties shall remain free to use, in the normal course of its business, its general

knowledge, skills and experience incurred before, during or after the discussions envisaged hereunder. (To this end, it is also recorded that nothing in this Agreement shall be construed as constituting an exclusive arrangement between the parties and both Parties shall remain free to explore market opportunities in the Field, unless otherwise agreed to in writing in a subsequent agreement.)

14. Parties to the NDA

THE CSIR, a statutory council, duly established under Act 46 of 1988,

and

The Bidder

(Name).....

Company registration number:.....,

with limited liability duly incorporated under the applicable laws of the Republic of South

Africa herein represented by

..... in his/her capacity as

..... and he/she being duly authorised thereto.

15. Contact Details for Purposes of Clause 10:

15.1. The CSIR

Physical Address:

Meiring Naude Road

Brummeria

Pretoria

0002

Postal Address:

PO BOX 395

Pretoria

0001

Email: Tender@csir.co.za

The Bidder (Name).....

.....

Physical Address:

.....

Postal Address:

.....

Email:

16. Signature (Bidder):

SIGNED ON THIS THE.....DAY

OF.....AT..... IN THE PRESENCE OF THE

FOLLOWING WITNESSES:

1.

2.